



## Guide to cable preparation for connecting MotoTRBO base station to the SmartPTT radioserver (based on PMLN5072)

### Components

Description	Quantity
MotoTRBO PMLN5072 Connector	1
Double shielded sound cable	1.6 m
USB male cable	1.6 m
Planar capacitor 2.2 $\mu$ F	1
Planar Resistor 100 $\Omega$	1
Stereo connector 3.5 mm	2
Black PVC shrink tube (diameter 5 mm)	20 cm
Red PVC shrink tube (diameter 12 mm)	2 cm
Green PVC shrink tube (diameter 12 mm)	2 cm
Printed circuit board blank (4 x 15 mm)	1
Single core copper fluoroplastic insulated cable (diameter 0.12 mm)	3 cm

*Ready Cable Picture*

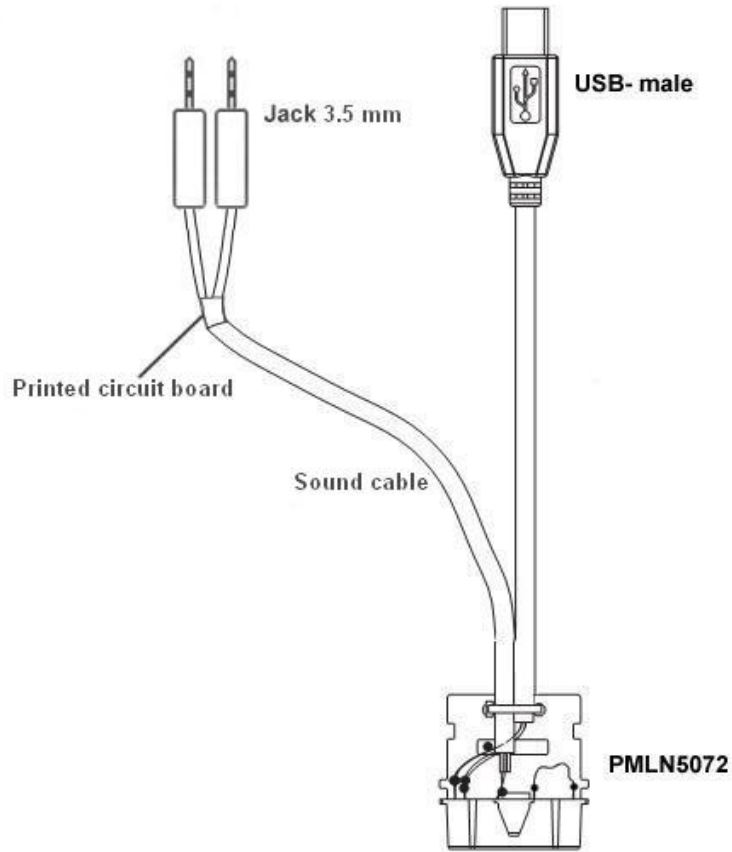

*SmartPTT Cable electrical schematic diagram*

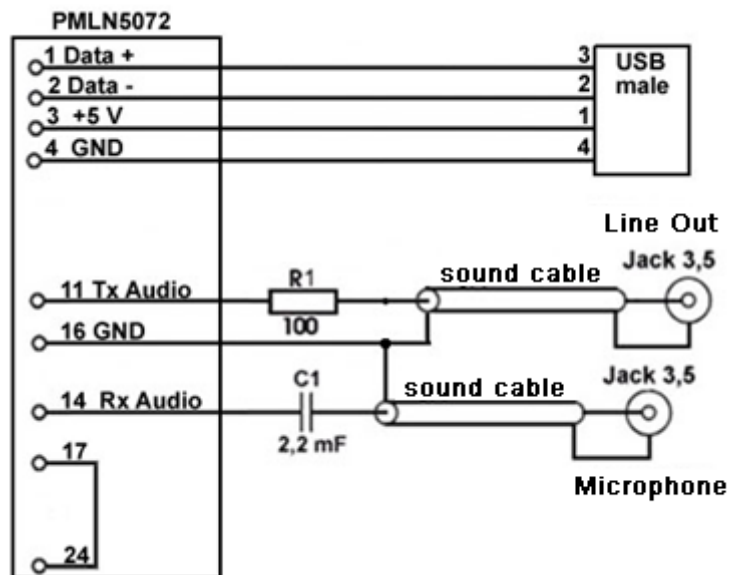

Planar resistor and capacitor are soldered on the prepared textolite printed circuit board (4 x 15 mm).

## Printed circuit board picture

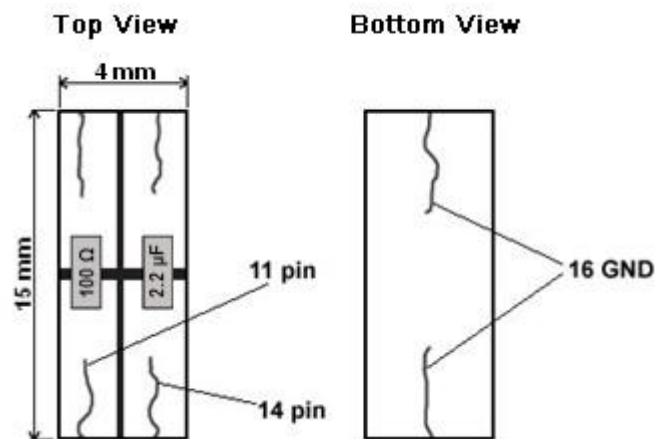

Steps to make the cable:

1. Cut out textolite printed circuit board (4 x 15 mm).
2. Mark the board in accordance with the picture above. Finally there must be 4 insulated metallized areas. Bottom side of the board must be fully metallized.
3. Solder planar resistor and capacitor in accordance with the picture.
4. Cut out 140 cm of doubled sound cable.
5. Split it on both sides (approximately by 12 mm) and twist the armature of both cables.
6. Press out the cable (both central wires and twisted armature) by means of MotoTRBO PMLN5072 contacts.
7. Put 2 cm of black PVC shrink tube (diameter 5 mm) on the cable
8. Fix the cable into PMLN5072 in accordance with the electrical diagram: Armature wire to contact 16, one of central wire to contact 11, another one to contact 14.
9. Shrink PVC shrink tube on the cable as close as possible to PMLN5072 (for better reliability)
10. Solder corresponding central wires on top of the board. Solder twisted armature to the bottom of the board.
11. Take rest 20 cm of sound cable. On the one side of the cable solder stereo connectors as following: Central wire to the first channel of the connector. The armature to the ground of the connector.
12. Prepare 2 pieces of black PVC shrink tube (diameter 5 mm) = 4 cm and put them on the cable for later heat shrinking on the board.
13. Solder prepared cable to the board. Central wires to the top of the board and the armature to the bottom of the board.
14. Shrink both pieces of PVC shrink tube on the board in two layers.
15. Use green PVC shrink tube to mark stereo connector connected to contact 11.
16. Use red PVC shrink tube to mark stereo connector connected to contact 14.
17. Use 4-wire cable (160 cm) with the USB male connector on the one side.
18. Press out the cable by means of PMLN5072 contacts.
19. Put 2 cm of black PVC shrink tube (diameter 5 mm) on the cable.

20. Connect the cable to PMLN5072 in accordance with the diagram. It is convenient to use standard color codes for wires: green – contact 1, white – contact 2, red – contact 3, black – contact 4.
21. Shrink PVC shrink tube on the cable as close as possible to PMLN5072 (for better reliability)
22. Use plastic clamp to fix both cables (sound and USB) on PMLN5072.
23. Press out single core copper fluoroplastic insulated cable (3 cm). It is possible to use some analog of this cable.
24. Use the cable to connect contacts 24 and 17 of PMLN5072.

### **SmartPTT cable check procedure**

Preliminary cable check is done by multimeter:

1. Check for absence of short circuits between armature and central wire of each sound cable.
2. Measure full (over the whole length of cable) resistance of central wire of the cable connected to contact 11 (marked by green) of PMLN5072. It must not exceed  $110\Omega$ .
3. Check presence of electrical connection on contact 14 (marked by red) of PMLN5072 as follows: Set multimeter to measure maximum possible resistance and measure the resistance over the whole length of cable. The resistance must grow together with the capacitor charge.
4. Check that all the connectors are reliably fixed in PMLN5072.